

Understanding and Specifying Protegé 433 Series Work Chairs

Understanding Protegé 433 Series

Details	148
Dimensions	150

Specifying Protegé 433 Series

Value Package Work Chair	152
Work Chairs	154
Multi-Use Chairs	156
Sled-Base Multi-Use Chairs	158

Work Chairs

Adjustable work chairs offer basic ergonomic comfort for people who have varied tasks and tend to be in and out of the office during the day. Features include adjustable seat height, back tension, and upright back lock. Also featured is the no front-rise seat—in other words, when you lean back, the front edge of the seat doesn't rise up, lifting your legs off the floor and cutting off circulation.

- Rally 457 Series
- Protegé 433 Series
- Cachet 487 Series

Adjustability Features

▶ See page 11 for a comparison to other chairs

Protegé 433 Series

Mechanisms

Advanced swivel-tilt	●
----------------------	---

Seat Adjustments

Pneumatic height	●
------------------	---

Back Adjustments

Upright back lock	●
-------------------	---

Back tension	●
--------------	---

Protegé 433 Series

Protegé is an economic, general-use solution with basic ergonomic features. Protegé is stylish, comfortable, and well suited for a wide range of tasks, including moderate computer use.

Outer back is plastic. Fully upholstered outer back is an option.



Five-arm base is standard.

Arms are available without arm caps or with soft vinyl arm caps.

Seat height adjusts with a 5" range from 16"H to 21"H with a pneumatic adjustment mechanism.

Hard, dual-wheel casters are provided for use on carpets. Soft, dual-wheel casters are available for use on hard floors or chair mats.

Product Details



Work and multi-use chairs are available with or without arms.



Multi-use chair bases are available in two styles: advanced swivel-tilt and sled base.

Adjustment Features

Seat Adjustments

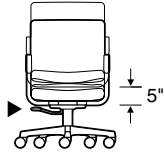

Seat height adjusts pneumatically. To lower, hold handle up while seated. To raise, hold handle up and keep your weight off the chair.

Back Adjustments



Back tension adjusts by turning knob. Turn knob clockwise to increase tension, counterclockwise to decrease.



Upright back lock. Flick switch forward to lock; flick switch back to tilt.

Surface Materials

► See surface materials on page 248 for specific availability or refer to the *Surface Materials Reference Manual* for further information.

Upholstery

- Fabric
- Fabric with soil-retardant treatment (option)
- Leather

Hard components

(base, arms, plastic arm caps, outer back, outer seat, frame, and casters)

- Monochromatic color from list of seating plastic color numbers will apply to all hard components.

Base

- Plastic color to match monochromatic color of other “hard components”

Outer back

- Plastic color to match monochromatic color of other “hard components”
- Fully upholstered

Arms and arm caps

- Plastic color to match monochromatic color of other “hard components”

Glides

- Plastic on sled base models

All Steelcase seating with standard upholstery fabrics complies with requirements of the BIFMA First Generation Voluntary Upholstered Furniture Flammability Standard, as well as the State of California Technical Bulletin 117. All standard seating is labeled to be in compliance with California TB117.

Programs & Services

► See the *Surface Materials Reference Manual* for further detail about programs and services offered for seating.

The Customer’s Own Material (COM) Program

offers the opportunity for customers to select fabrics that are not offered through the standard Steelcase surface materials program for use on Steelcase products. Through the COM program, Steelcase will test your materials for application on Steelcase products. Once approved, you can place your order.

Steelcase will facilitate the entire ordering process and give you a production schedule. Steelcase will order the COM fabric directly from the textile manufacturer. For up-to-date information regarding fabric test results for all COM fabrics and details regarding yardage requirements for most Seating lines, visit the COM Web site. To locate the COM Web site:

- Visit www.steelcase.com
- Click on “Knowledge & Design”
- Select “Customer’s Own Material”

Soil retardants are treatments that provide long-term soil and stain resistance to a fabric without affecting the shade or the integrity of the fabric. The following Steelcase Textiles are available pre-treated with soil retardant. (You do not need to select the soil-retardant option for these fabrics and incur the upcharge.)

- Jacks
- Link
- Regis
- Roulette
- Skittles
- Spyder

Soil-retardant treatment is available on all other seating fabrics at an additional upcharge per seating unit. To order this option, please select “Soil-Retardant Treatment” under “Optional Accessories.”

For soil-retardant treatment on COMs, please select “Soil-Retardant Treatment” under “Optional Accessories.” Minimums or additional yardage may be required. Please contact the vendor directly for specific information.

Extended lead times may be necessary for this service.

Contact your Steelcase Solutions Fulfillment Team Representative at 1.888.STEELCASE (1.888.783.3522).

Fire Codes

► See pages 254–255 for upholstery fabrics available for use with FCS modification.

Steelcase offers Fire Code Seating modification (FCS) on nearly all seating models. The most rigorous fire codes in the nation have been developed in California, and the Steelcase FCS modification is designed to meet those codes. Fire Code Seating (FCS) indicates that a product is constructed to meet the strict fire code requirements of high public occupancy areas such as theaters, meeting rooms, and lobbies. The FCS standards will meet both the State of California Home Furnishing Technical Bulletin 133 (Cal TB 133) and Boston Fire Code (BFC). Boston adopted the California Home Furnishing Technical Bulletin TB 133 test standard in 1992.

Local codes may have special requirements for upholstery.

Dimensions

► Page 150

Resources

Printed Materials

- Protegé Brochure (04-0000171)
- Seating Overview (06-0000890)

Dimensions

Protégé 433 Series

Features	Overall Depth	Width	Height	Seat Depth	Functional Seat Depth	Seat Width	Seat Height from Floor	Back Width	Back Height from Seat
----------	---------------	-------	--------	------------	-----------------------	------------	------------------------	------------	-----------------------

Protégé 433 Series

Work Chairs

Pneumatic	21 1/4"	23"	33 3/4"–38 3/4"	17 1/2"	16"	19 1/2"	16"–21"	19"	19 1/4"
-----------	---------	-----	-----------------	---------	-----	---------	---------	-----	---------

Multi-Use Chairs

Fixed Height	21 1/4"	23"	35 1/4"	17 1/2"	16"	19 1/2"	17 1/4"	19"	19 1/4"
Sled Base	21 1/4"	23"	35"	17 1/2"	16"	19 1/2"	18 1/4"	19"	19 1/4"

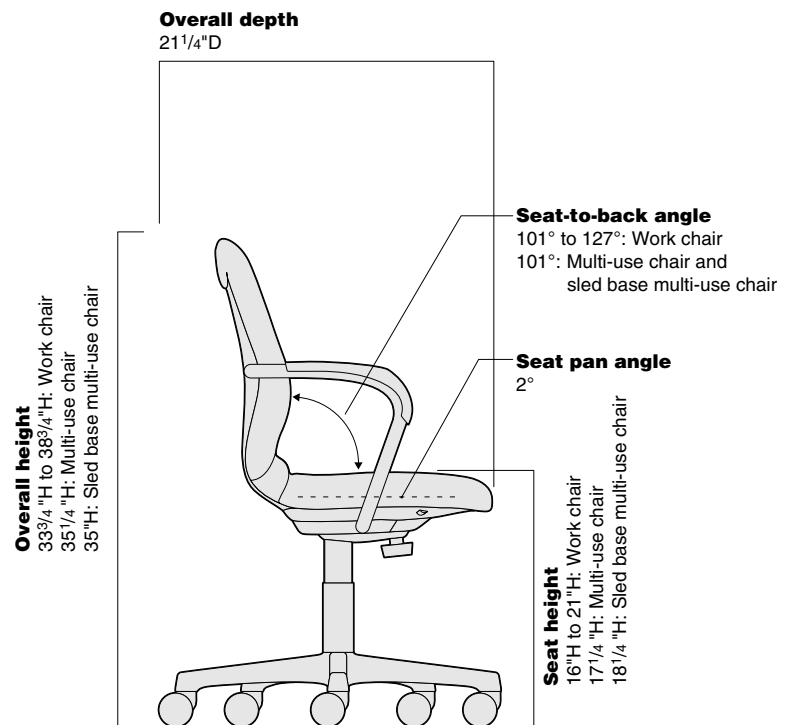
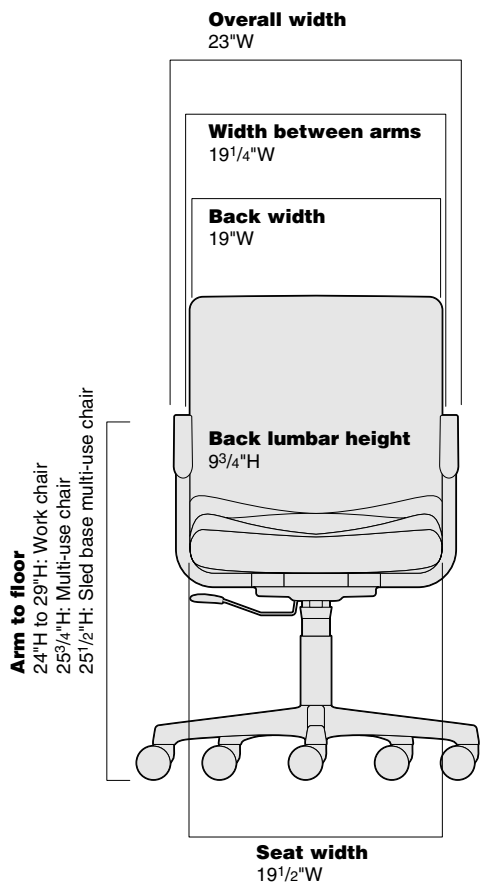

• Back Lumbar Height	• Width Between Arms	• Arm to Floor	• Arm Height from Seat	• Seat Pan Angle	• Angle Between Seat and Back
----------------------	----------------------	----------------	------------------------	------------------	-------------------------------

Work Chairs

9¾"	19¼"	24"-29"	7¾"	2°	101°-127°
-----	------	---------	-----	----	-----------

Multi-Use Chairs

9¾"	19¼"	25¾"	7¾"	2°	101°
9¾"	19¼"	25½"	7¾"	2°	101°

Protégé 433 Series Value Package Work Chair

Buzz2 Fabric on Seat and Back
Black Plastic Finish on Frame



Tip: This value package allows you to obtain the pre-selected features at a lower price than if specifying as a standard model number.

Tip: Options or substitutions are not available on this value package.

Standard Includes		Required to Specify
<ul style="list-style-type: none"> ▶ Need help? Product details, page 148 	<ul style="list-style-type: none"> • Advanced swivel-tilt mechanism • Pneumatic seat-height adjustment • Arms with soft arm caps • Back tension adjustment • Seat and back: Buzz2 fabric • Five-arm base: black plastic • Frame: black plastic • Hard dual-wheel casters: black 	<ul style="list-style-type: none"> 1 Style number 2 Buzz2 fabric color number ▶ See <i>Surface Materials</i>, page 248.

Specification Information	
Style Number	U.S. Price
PROTEGEV	\$581
:	:
:	:

▶ Detailed dimensions, page 150

US

For **164** U.S., multiply all **162** U.S. prices by 1.03.
Multiply **164** U.S. by 1.2 for **138** Canadian price.
▶ See page 1 for details.

Protegé 433 Series Work Chairs



Standard Includes		Required to Specify
<ul style="list-style-type: none"> ▶ Need help? Product details, page 148 	<ul style="list-style-type: none"> • Advanced swivel-tilt mechanism • Arms, if selected: plastic color to match base • Outer back: plastic color • Back tension adjustment • Upholstery: fabric price group 1 • Five-arm base: plastic color • 2½"-diameter, hard composition, dual-wheel casters: plastic color to match base 	<ol style="list-style-type: none"> 1 Style number 2 Plastic color number for base, outer back, arms, and casters 3 Fabric color number for upholstery 4 Options, if selected (see below) <ul style="list-style-type: none"> ▶ See <i>Surface Materials</i>, page 248.

Options	U.S. Price	Required to Specify
Surface Materials	Upholstery	
	<ul style="list-style-type: none"> • Fabric price group 1 No cost • Fabric price group 2 +\$ 20 • Fabric price group 3 +\$ 40 • Fabric price group 4 +\$ 55 • Fabric price group 5 +\$ 70 • Fabric price group 6 +\$100 • Fabric price group 7 +\$140 • Fabric price group 8 +\$185 • Fabric price group 9 +\$220 • Fabric price group 10 +\$255 • Customer's Own Material (COM) +\$ 30 • Steelcase leather upholstery +\$566 • Customer's Own Leather (COL) +\$335 	<ul style="list-style-type: none"> Specify fabric color number. Specify fabric color number. Specify fabric color number. Specify fabric color number. Specify fabric color number. Specify fabric color number. Specify fabric color number. Specify fabric color number. Specify fabric color number. Specify fabric color number. ▶ See <i>Surface Materials Reference Manual</i> to specify. Add suffix S to style number and specify leather color number. Add suffix S to style number. ▶ See <i>Surface Materials Reference Manual</i> to specify. Add suffix F to the style number. Specify <i>with soil-retardant treatment</i>.
	<ul style="list-style-type: none"> • Fire Code Seating (FCS) +\$ 55 • Soil-retardant treatment applied to upholstery fabric +\$ 20 	
	Fully upholstered	
	<ul style="list-style-type: none"> • Fabric fully upholstered outer back and outer seat +\$ 94 • Steelcase leather fully upholstered outer back and outer seat +\$982 • Customer's Own Leather (COL) fully upholstered outer back and outer seat +\$522 	<ul style="list-style-type: none"> Add suffix U to the style number. Add suffix SU to the style number and specify leather color number. Add suffix SU to the style number. ▶ See <i>Surface Materials Reference Manual</i> to specify.
Casters	<ul style="list-style-type: none"> • Soft, dual-wheel casters +\$ 18 	<ul style="list-style-type: none"> Specify <i>with soft casters</i>.

Tip: Always add suffixes in alphabetical order when specifying options to Protegé seating.

Tip: Fire Code Seating (FCS) option is available with certain upholstery fabric choices only.
▶ Pages 254–255

▶ Detailed dimensions, page 150

US 

For **164** U.S., multiply all **162** U.S. prices by 1.03.
Multiply **164** U.S. by 1.2 for **138** Canadian price.
▶ See page 1 for details.

Specification Information

Arms



•Style
•Number
•U.S.
•Base
•Price

**Arms with
Soft Arm Caps**



•Style
•Number
•U.S.
•Base
•Price

Pneumatic

4331213

\$619

4331223

\$645

Pneumatic with Upright Back Lock

4331413

\$664

4331423

\$690

Without Arms



•Style
•Number
•U.S.
•Base
•Price

Pneumatic

4331203

\$586

Pneumatic with Upright Back Lock

4331403

\$631

US 
 For **164** U.S., multiply all
162 U.S. prices by 1.03.
 Multiply **164** U.S. by 1.2 for
138 Canadian price.
 ▶ See page 1 for details.

Protegé 433 Series Multi-Use Chairs



Standard Includes	Required to Specify
<ul style="list-style-type: none"> ▶ Need help? Product details, page 148 • Fixed height with advanced swivel-tilt mechanism • Arms, if selected: plastic color to match base • Outer back: plastic color • Back tension adjustment • Upholstery: fabric price group 1 • Five-arm base: plastic color • 2½"-diameter, hard composition, dual-wheel casters: plastic color to match base 	<ol style="list-style-type: none"> 1 Style number 2 Plastic color number for base, outer back, arms, and casters 3 Fabric color number for upholstery 4 Options, if selected (see below) <p>▶ See <i>Surface Materials</i>, page 248.</p>

Options	U.S. Price	Required to Specify
<p>Surface Materials</p> <p>Upholstery</p> <ul style="list-style-type: none"> • Fabric price group 1 • Fabric price group 2 • Fabric price group 3 • Fabric price group 4 • Fabric price group 5 • Fabric price group 6 • Fabric price group 7 • Fabric price group 8 • Fabric price group 9 • Fabric price group 10 • Customer's Own Material (COM) • Steelcase leather upholstery • Customer's Own Leather (COL) • Fire Code Seating (FCS) • Soil-retardant treatment applied to upholstery fabric <p>Fully upholstered</p> <ul style="list-style-type: none"> • Fabric fully upholstered outer back and outer seat • Steelcase leather fully upholstered outer back and outer seat • Customer's Own Leather (COL) fully upholstered outer back and outer seat <p>Casters</p> <ul style="list-style-type: none"> • Soft, dual-wheel casters 	<p>No cost</p> <p>+\$ 20</p> <p>+\$ 40</p> <p>+\$ 55</p> <p>+\$ 70</p> <p>+\$100</p> <p>+\$140</p> <p>+\$185</p> <p>+\$220</p> <p>+\$255</p> <p>+\$ 30</p> <p>+\$566</p> <p>+\$335</p> <p>+\$ 55</p> <p>+\$ 20</p> <p>+\$ 94</p> <p>+\$982</p> <p>+\$522</p> <p>+\$ 18</p>	<p>Specify fabric color number.</p> <p>Specify fabric color number.</p> <p>Specify fabric color number.</p> <p>Specify fabric color number.</p> <p>Specify fabric color number.</p> <p>Specify fabric color number.</p> <p>Specify fabric color number.</p> <p>Specify fabric color number.</p> <p>Specify fabric color number.</p> <p>Specify fabric color number.</p> <p>▶ See <i>Surface Materials Reference Manual</i> to specify.</p> <p>Add suffix S to style number and specify leather color number.</p> <p>Add suffix S to style number.</p> <p>▶ See <i>Surface Materials Reference Manual</i> to specify.</p> <p>Add suffix F to the style number.</p> <p>Specify <i>with soil-retardant treatment</i>.</p> <p>Add suffix U to the style number.</p> <p>Add suffix SU to the style number and specify leather color number.</p> <p>Add suffix SU to the style number.</p> <p>▶ See <i>Surface Materials Reference Manual</i> to specify.</p> <p>Specify <i>with soft casters</i>.</p>

Tip: Always add suffixes in alphabetical order when specifying options to Protegé seating.

Tip: Fire Code Seating (FCS) option is available with certain upholstery fabric choices only.
▶ Pages 254–255

▶ Detailed dimensions, page 150

US

For **164** U.S., multiply all **162** U.S. prices by 1.03.
Multiply **164** U.S. by 1.2 for **138** Canadian price.
▶ See page 1 for details.

Specification Information

Arms



• **Style Number**
:
:
:
:
:

• **U.S. Base Price**
:
:
:
:
:

Arms with Soft Arm Caps



• **Style Number**
:
:
:
:
:

• **U.S. Base Price**
:
:
:
:
:

Multi-Use Chairs

Fixed Height

4333013	\$590	4333023	\$616
:	:	:	:

Without Arms



• **Style Number**
:
:
:
:
:

• **U.S. Base Price**
:
:
:
:
:

Multi-Use Chairs

Fixed Height

4333003	\$557
:	:

US 

For **164** U.S., multiply all **162** U.S. prices by 1.03.
Multiply **164** U.S. by 1.2 for **138** Canadian price.
▶ See page 1 for details.

